

Spartan Make Digital Torque Wrench



Overview

1.1 Main purpose and applicable range

A ratchet-head digital display torque wrench and replaceable head digital display torque wrench are different from normal torque wrench, wherein the AWJC replaceable head wrench with its attached ratchet head can be replaced with an open head, a plum blossom head, a movable opening head, etc at any time. Both have powerful operating functions, including torque setting; unit setting; mode setting; value storage; value clearing; value output and user correction function. With easy operation, the digital display is installed to reduce the requirement on the operator. It is applicable to the fastening and control of bolts in automobile industry, machinery industries.

Office No- 114, First Floor, Dhuri Commerce Plaza,
Vasai Station (E), Opposite Bus Depot,
Dist : PALGHAR- 401208

1.2 Functions and features

- 1.2.1 Reading value of digital display torque
- 1.2.2 Accuracy of $\pm 2\%$ by clockwise, and $\pm 2.5\%$ by counterclockwise (Max.operating range is within 20~100%)
- 1.2.3 It can be operated by both clockwise and counterclockwise
- 1.2.4 Peak hold and real time mode
- 1.2.5 Buzzer and LCD indication (when the torque value is pre-set)
- 1.2.6 Four kinds of engineering units (ft.lb、 in.lb、 N.m、 kgf.cm)
- 1.2.7 99 groups of recorded values can be stored
- 1.2.8 Automatic shutdown in 5 minutes

1.3 Product model and selection

①: Max.accuracy

Accuracy
$\pm 2\%$ by clockwise/ $\pm 2.5\%$ by counterclockwise

②: Is it with communication function?

Communication and transmission functions	
None	None

1.4 Functions and names of each component -

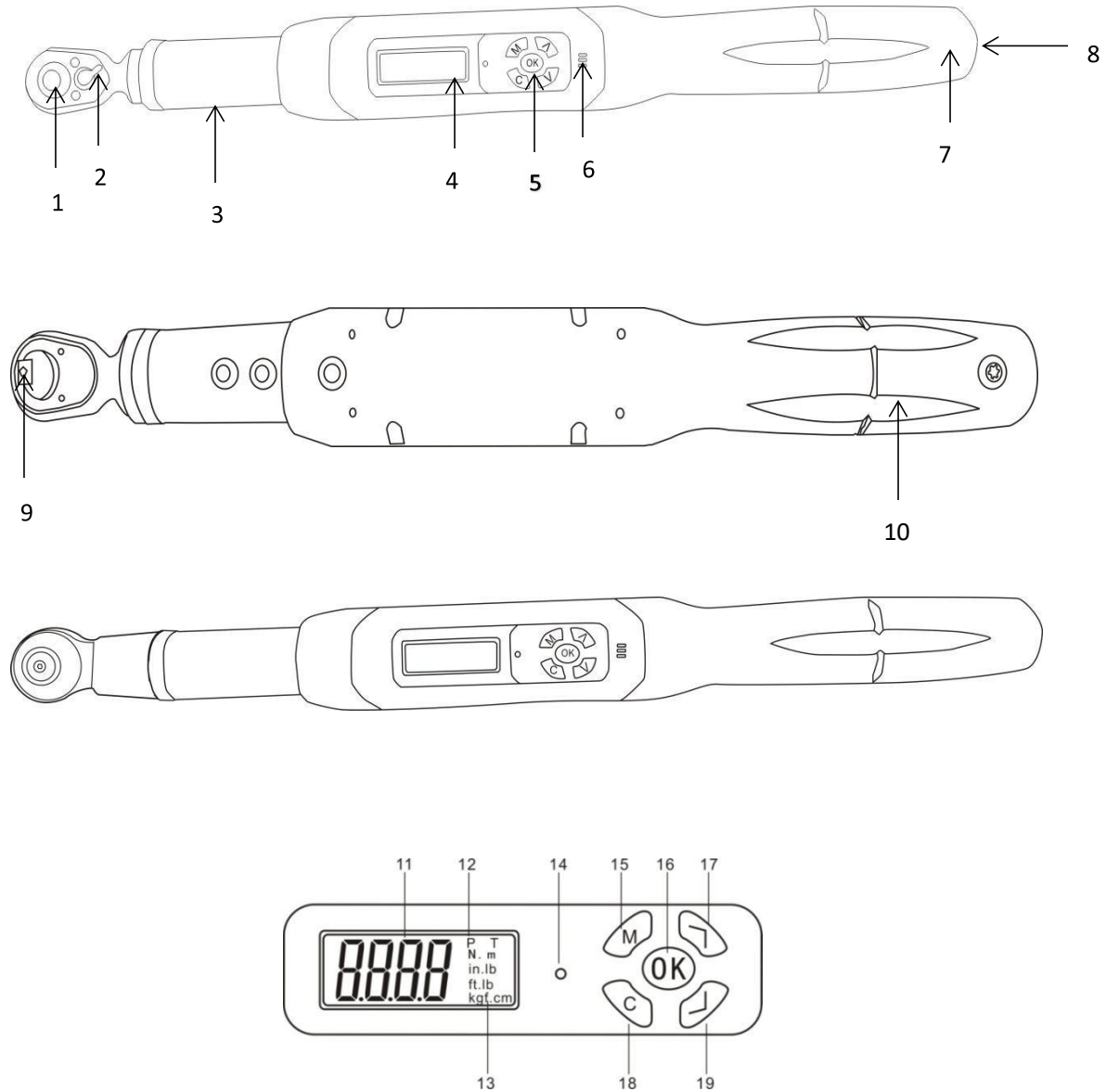

1. Two-way ratchet head

2. Steering paddle 3.

Main body

4. LCD screen

5. Key

6. Buzzer

7. Battery box

8. Battery cover

9. Ratchet torque square head

10. Handle

11. Torque value

12. P (peak mode), T (real time mode)

13. Unit (N.m, in.lb, ft.lb, kgf.cm)

14. LED indicator

15. Menu key

16. Confirm key

17. Upward key

18. Cancel key

19. Downward key

Office No- 114, First Floor, Dhuri Commerce Plaza,
 Vasai Station (E), Opposite Bus Depot,
 Dist : PALGHAR- 401208

Technical Specification of Product -

Model	010	030	030	060	085	135	135	200	340	500	850
	010	30A	30B	060	085	135	135	200	340		
Min.scale value	0.01					0.1					
Max. operating range (N.m)	10N.m/ 7.37ft.lb /88.50in .lb/101. 97kgf.c m	30N.m/ 22.12ft.l b/265.5i n.lb/305 .91kgf.c m	30N.m/ 22.12ft.l b/265.5i n.lb/305 .91kgf.c m	60N.m/ 44.25ft.l b/531.0 4in.lb/6 11.82kg f.cm	85N.m/ 62.69ft.l b/752.3 1in.lb/8 66.75kg f.cm	135N.m /99.57ft. lb/1195i n.lb/137 6.61kgf. cm	135N.m /99.57ft. lb/1195i n.lb/137 6.61kgf. cm	200N.m /147.5ft. lb/1770i n.lb/203 9.43kgf. cm	340N.m /250ft.lb /3009in. lb/3467. 03kgf.c m	500N.m /4424in. lb/368.7 ft.lb/509 8.58kgf. cm	850N.m /7521in. lb/626.8 ft.ln/866 7.58kgf. cm
Connectors (inches)	1/4		3/8			1/2			3/4		
Size of replaceable head connection	9*12					14*18					
Setting range of buzzer (N.m)	0.5~10	1.5~30	1.5~30	3~60	4.25~85	6.75~135	6.75~135	10~200	17~340	25~500	42.5~850
Length	390		420			535		655	950	1220	
Accuracy*1	Clockwise: ±2% Counterclockwise:±2.5%					Clockwise: ±2.5% Counterclockwise:±3.5%					
Storage capacity of materials	100										
Operating mode	Peak hold (P)/real time mode (T)										
Unit	N.m, in.lb, ft.lb, kgf.cm										
Type of ratchet head	Two-way ratchet head										
Teeth number of ratchet head	36									48	
Number of key	5										

Office No- 114, First Floor, Dhuri Commerce Plaza,
Vasai Station (E), Opposite Bus Depot,
Dist : PALGHAR- 401208

Battery	2 sets of 1.5V#5 battery
Operating temperature	-10°C~60°C
Storage temperature	-20°C~70°C
Humidity	It can reach 90% under no condensation
Drop testing height	1m
Vibration testing condition*2	10G
Life test*3	10000times

Use Method -

3.1 Turn ON/FF by zero clearing: press C key to turn on, if the power value appears after the turn on, press C key to clear, under no operation, enter the sleeping mode for 5 minutes, press C key to start, and also press and hold C key to turn off.

3.2 Setting method of pre-set value: Under normal power-on state, shortly press M key on the measurement interface, and switch UP/DN key to obtain your required pre-set value. After setting the pre-set value, the system will automatically save the pre-set value, and continuously press M key until returning back to the measurement interface.

3.3 Setting methods of real time and peak modes: This product starts by real time mode T in default. If you want to switch to the peak mode P, you need to press M key twice shortly on the measurement interface, and pops up NODE, then you can select the T.P switching mode by UP/DN keys. After the selection is completed, press M continuously until returning back to the measurement interface.

3.4 Setting methods of unit mode: This product has totally four kinds of unit modes for selection such as N.m、 in.lb、 ft.lb、 kgf.cm, which can be switched according to actual use condition. The modes are set up by press M key 3 times shortly on the measurement interface, and pops up UNLT, then the required unit modes can be selected by UP/DN keys. After the selection is completed, press M key continuously until returning back to the measurement interface.

Office No- 114, First Floor, Dhuri Commerce Plaza,
Vasai Station (E), Opposite Bus Depot,
Dist : PALGHAR- 401208

3.5 Data save and checking method: The data save can be used under P peak mode, and the measured data can be discarded by directly pressing C key, and press OK key to save. After save is completed, you will automatically return back to the measurement interface for re-testing. By such circulation, max. data can be saved to 99 groups (data number is 001.002 099 by sequence).

Data check. Press M key to check the saved data group on the measurement interface (display 0000 under no saved data) and data number can be checked by UP/DN keys, then if no operation lasts for 2 seconds, it will display the detailed force values saved by this number. After checking, press M key continuously until returning back to the measurement interface.

3.6 Clearing data storage values: Shortly press M key for 5 times on the measurement interface to pop up CLR, and press C key to pop up No?, then press C key again to confirm clear, which display DEL for completion, then returning back to the measurement interface. (If in No? Press M key on the interface to discard and delete, then returning back to the measurement interface. Note: Data clearing is one-time clear which completely clears all the data without single operation)

Precautions –

- 4.1 In order to maintain good accuracy, it is recommended to re-calibrate one time approximately every year.
- 4.2 Over-torque may cause damage or loss of accuracy (more than 105% of the maximum torque range).
- 4.3 Do not shake the wrench vigorously or drop the wrench to the ground.
- 4.4 Do not use the wrench as a hammer.
- 4.5 Do not place the wrench in a place with high temperature, high humidity or direct sunlight.
- 4.6 Do not use the wrench near water.
- 4.7 If you accidentally wet the wrench, dry it with a dry towel immediately. Salt in the sea can damage the wrench.
- 4.8 Do not use organic solvents to clean the wrench, such as alcohol or paint thinner.
- 4.9 Do not place the wrench close to the magnetic object.
- 4.10 Do not place the wrench in a place with a lot of dust or sand, which will cause serious damage to the wrench.
- 4.11 Do not heavily press LCD screen.

Battery treatment

- 5.1 If you do not use the torque wrench for a long time, please take out the battery.
- 5.2 When you need to travel long distances or in a cold area, please prepare a spare battery.

Office No- 114, First Floor, Dhuri Commerce Plaza,
Vasai Station (E), Opposite Bus Depot,
Dist : PALGHAR- 401208

5.3 Do not mix batteries of different brands, and do not mix old and new batteries.

5.4 Sweat, oil and other factors will hinder the contact of the battery electrode, please wipe the battery clean before putting the torque wrench.

5.5 Please discard the used battery at the designated recycling location. Do not put the battery in a fire.

Detailed list of accessories attached with the unit

1	Drying agent	1 bag
2	5V battery	1 pair
3	Key for battery box	1 set
4	User's manual	1 copy
5	Certificate Warranty card	1 copy
Note: Packaging accessories for ratchet head and replaceable head are unified		